

# **INSTRUMENTATION AND CONTROL**

## **TUTORIAL 3 – SIGNAL PROCESSORS AND RECEIVERS**

This tutorial provides an overview of signal processing and conditioning for use in instrumentation and automatic control systems. It is provided mainly in support of the EC module D227 – Control System Engineering. This tutorial is mainly descriptive.

On completion of this tutorial, you should be able to do the following.

- Explain a basic measurement system.
- Describe the various types of signals and their conversion.
- Explain the principles of a selection of signal processors and conditioners.
- Explain in some details the principles Analogue/Digital processing.
- Explain the principles of a range of signal receivers.

In order to complete the theoretical part of this tutorial, you must be familiar with basic mechanical and electrical science.

## 1. INTRODUCTION

A basic instrument system consists of a sensor (tutorial 2), a processor and a receiver. This tutorial is about the processor and the receiver. The technology used in signal processing is also important for automatic control systems.



Figure 1

## 2. SIGNAL PROCESSING AND CONDITIONING

You should now be familiar with transducers and sensors. These were PRIMARY TRANSDUCERS. We must now examine how to process the output of the transducers into the form required by the rest of the instrument system. These may also be transducers but in this case, SECONDARY TRANSDUCERS. Most modern equipment works on the following standard signal ranges.

- Electric 4 to 20 mA
- Pneumatic 0.2 to 1.0 bar
- Digital standards

Older electrical equipment use 0 to 10 V.

The advantage of having a standard range is that all equipment is sold ready calibrated. This means that the minimum signal (Temperature, speed, force, pressure and so on) is represented by 4 mA or 0.2 bar and the maximum signal is represented by 20 mA or 1.0 bar. The primary transducer will not produce these standard ranges so the purpose of processing and conditioning is usually to convert the output into the standard range.

The vast array of instrumentation and control equipment available uses many forms of signals. Here is a summary.

ELECTRICAL - Voltage, current, digital.

MECHANICAL - Force and movement.

PNEUMATIC AND HYDRAULIC – Pressure and flow.

OPTICAL – High speed digital signal transmission.

RADIO – Analogue and digital transmission.

ULTRA VIOLET – Similar application to radio over short ranges.

Processing may do the following things.

- Change the level or value of the signal (e.g. voltage level)
- Change the signal from one form to another. (e.g. current to pneumatic)
- Change the operating characteristic with respect to time.
- Convert analogue and digital signals from one to the other.

First let's examine those processors which change the level or value of the signal.

## 2.1 AMPLIFIERS

Amplifiers may amplify VOLTAGE, CURRENT or BOTH in which case it is a POWER AMPLIFIER.

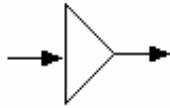

Amplifier gain may be expressed as a ratio or in decibels. The letter W indicates it refers to power gain. The gain in dbW is given by  $\text{Gain(dbW)} = 10 \log_{10} \frac{\text{Power Output}}{\text{Power Input}}$

Figure 2

### WORKED EXAMPLE No.1

Calculate the power gain of an amplifier which has an input of 5 mW and an output of 6 Watts.

### SOLUTION

$$\text{Gain} = G = 10 \log 6/0.005 = 10 \log 1200 = 30.79 \text{ dbW}$$

In practice, an amplifier generates some noise and the input and output terminals have a resistance that governs the ratio of current to voltage. A model is shown in which a noise generator is indicated and input and output resistors.

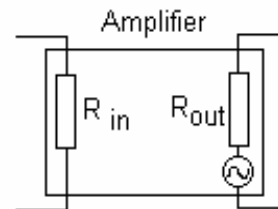

Figure 3

Since electric power into a resistive load is given as

$$P = I^2 R = \frac{V^2}{R} \quad \text{then} \quad \text{Gain(dbV)} = 10 \log_{10} \frac{V_{\text{out}}^2}{V_{\text{in}}^2} = 20 \log_{10} \frac{V_{\text{out}}}{V_{\text{in}}}$$

The letter V indicates it is a voltage gain.

### WORKED EXAMPLE No.2

Calculate the gain of a VOLTAGE amplifier with an input of 2 mV and output 10 V.

### SOLUTION

$$G = 20 \text{ Log}_{10} 10/0.002 = 73.98 \text{ dbV}$$

## DIFFERENTIAL AMPLIFIERS

These have two inputs and the difference between them is amplified. The electronic symbol is shown.

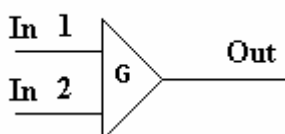
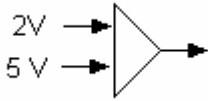

Figure 4

$$\text{Voltage Gain} = 20 \log_{10} \frac{V_{\text{out}}}{(V_2 - V_1)}$$

### WORKED EXAMPLE No.3

Find the output voltage if the gain 15 db.



### SOLUTION

$$\begin{aligned} \text{Input} &= 5 - 2 = 3 \text{ V} & G = 15 &= 20 \log_{10}(V_{\text{out}}/3) \\ 15/20 &= 0.75 = \log_{10}(V_{\text{out}}/3) & \text{Antilog } 0.75 &= 5.623 = (V_{\text{out}}/3) & V_{\text{out}} &= 16.87 \text{ V} \end{aligned}$$

## 2.2 ATTENUATORS

Sometimes a signal is too big and must be reduced by attenuating it. Electrical signals are attenuated with resistors which dissipate the electric power as heat. Step down transformers and gear boxes for example, are not strictly attenuators because they reduce the level, not the power. The gain of an attenuator in db is negative as the next example shows.

### WORKED EXAMPLE No.4

Calculate voltage the gain of an attenuator with an input voltage of 12 V and output voltage of 2 V.

### SOLUTION

$$G = 20 \log_{10} (2/12) = -15.56 \text{ dBV}$$

### SELF ASSESSMENT EXERCISE No.1

1. Calculate the power out put of an amplifier that has an input of 20 mW and a gain of 20 dB.  
(Answer 2 W)

2. Calculate the voltage output of the differential amplifier shown if the gain is 12 dbV

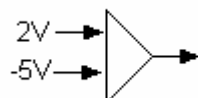

(Answer -27.87 V)

3. Calculate the power gain of an attenuator that has an input of 2.5 Watts and an output of 0.5 Watt.  
(Answer -6.99 dbW)

The term amplification is often used when the level of a signal is increased but not the power. Strictly speaking, such devices should be called TRANSFORMERS. For example an A.C. electric transformer may increase the voltage but not the power. We have voltage amplifiers and current amplifiers which do not necessarily change the power level.

## 2.3 TRANSFORMERS

### ELECTRICAL

Many devices only change the level of a signal without changing the power. A voltage amplifier is one example. An electrical transformer for alternating voltages basically consists of two windings, a primary and a secondary. The coils are wound on a magnetic core.

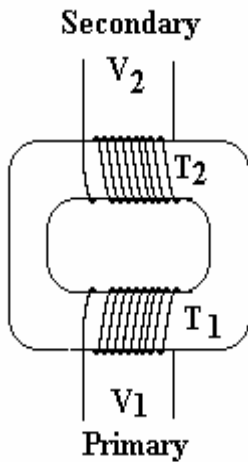

Figure 5

The primary coil has the input a.c. voltage applied and a.c. current flows according to the reactance. The flux produced is concentrated in the core and passes around the core. It follows that the same flux cuts the turns on the secondary coil and so an e.m.f will be generated in the secondary coil. The flux depends upon the number of turns  $T_1$  and the same flux cuts the secondary. The e.m.f in the secondary will depend on the number of turns  $T_2$ . It follows that  $V_1/V_2 = T_1/T_2$

In an ideal transformer there is no energy loss and so the power in and power out are equal.  $V_1 i_1 = V_2 i_2$ . It follows that if the voltage is stepped down, the current is stepped up and vice versa.

### WORKED EXAMPLE No.5

A transformer has 1200 turns on the primary coil and 200 on the secondary. If the input is 110 V a.c. what is the ideal output?

### SOLUTION

$$V_1/V_2 = T_1/T_2$$

$$110/V_2 = 1200/200 = 6$$

$$V_2 = 110/6 = 18.33 \text{ V a.c.}$$

### MECHANICAL

Mechanical transformers are levers and gear boxes which change movement, force, speed and torque but not the power. They are used in many instruments (e.g. a mechanical pressure gauge and the nozzle flapper system described later).

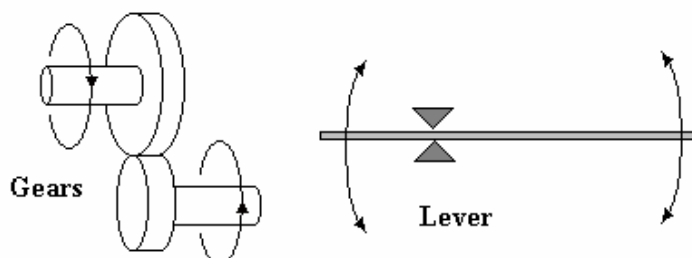

Figure 6

The gear ratio is in direct proportion to the pitch circle diameters (mean diameters) or number of teeth on each wheel.

The lever movements at the ends are in direct proportion to the length each side of the fulcrum.

## HYDRAULIC

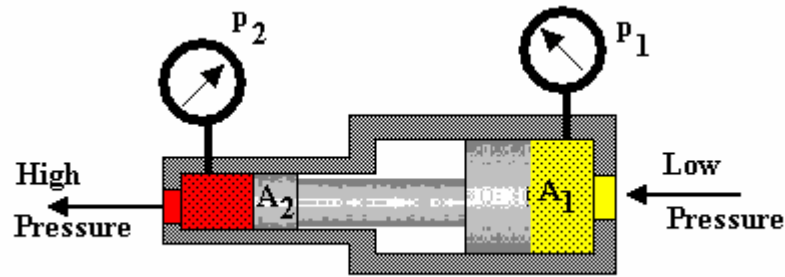

Figure 7

The hydraulic pressure amplifier shown increases the pressure in direct proportion to the areas of the pistons. It is also called an intensifier.

### WORKED EXAMPLE No.6

The large piston is 40 mm diameter and the smaller piston is 10 mm diameter. Calculate the pressure ratio.

### SOLUTION

The force on the input piston = Force on the output piston.

$$F = A_1 p_1 = A_2 p_2$$

$$p_2/p_1 = A_1/A_2 = (\pi D_1^2/4) \div (\pi D_2^2/4) = D_1^2/D_2^2 = 40^2/10^2 = 16$$

### SELF ASSESSMENT EXERCISE No.2

1. An electrical transformer must produce 12 V a.c. output from 240 V a.c. input. The primary has 2000 turns. How many turns are needed on the secondary? (Answer 100)
2. A pressure intensifier must increase the pressure from 10 bar to 100 bar. What must be the ratio of the piston diameters? (Answer 3.162/1)
3. A lever must magnify the movement of a mechanism from 0.1 mm to 2 mm. What must be the ratio of the lengths either side of the fulcrum? (Answer 20/1)
4. A pair of simple gears must magnify the rotation angle by 4/1. If there are 20 teeth on the small gear, how many must there be on the large gear? (Answer 80 teeth)

Now let's examine processors which change the form of the signal.

## 2.4 SIGNAL CONVERTERS

Signal converters change the signal from one form to another. Where ever possible, these are the standard inputs and output ranges.

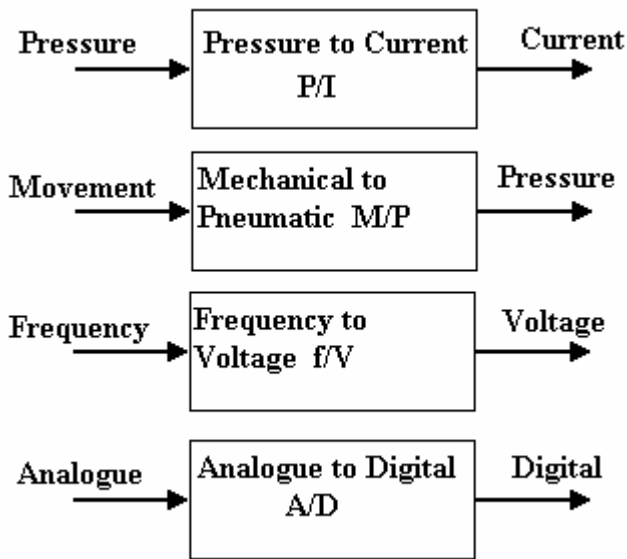

Normally we show them on a block diagram as a box with an input and output with a label to say what it does. Here are some examples.

All these examples have opposite versions i.e. I/P, P/M and so on.

Most signal converters have two adjustments – zero and range and this is explained in the next tutorial.

Figure 8

### NOZZLE – FLAPPER and DIFFERENTIAL PRESSURE CELLS

The nozzle – flapper system is widely used in D.P. cells. The form shown below converts differential pressure (e.g. from a differential pressure flow meter) into a standard pneumatic signal. This is widely used in the control of air operated pipeline valves.

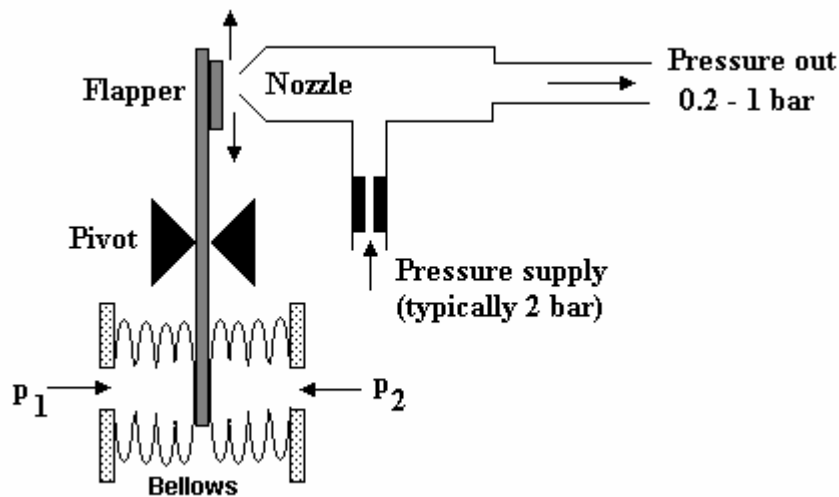

Figure 9

The bellows respond to the differential pressure and moves the lever. This moves the flapper towards or away from the nozzle. The air supply passes through a restrictor and leaks out of the nozzle. The output pressure hence depends on how close the flapper is to the end of the nozzle. The range of the instrument is adjusted by moving the pivot and the zero position is adjusted by moving the relative position of the flapper and nozzle.

This system is used in a variety of forms. Instead of bellows, a bourdon tube might be used and this is operated by an expansion type temperature sensor to produce a temperature - pneumatic signal converter.

## **ELECTRICAL D.P. CELLS**

These provide the same functions as the pneumatic versions but given an output of 4 – 20 mA using electrical pressure transducers. They are typically used with D.P. flow meters.



Figure 10

## **CURRENT/PRESSURE CONVERSION**

The pictures below show typical units for converting 4 – 20 mA into 0.2 – 1 bar and vice versa. They contain adjustments for range and zero. They are widely used for converting the standard pneumatic and electric signals back and forth. They can also be adjusted to work with non standard inputs to convert them into a standard form.



Current to Pressure Converter (I/P)



Pressure to Current Converter (P/I)

Figure 11

## ANALOGUE – DIGITAL CONVERSION

So many modern systems now use digital signals that it is important to appreciate how analogue signals are processed into digital form and vice versa. Analogue to digital conversion is a process of turning an analogue voltage or current into a digital pattern which can be read by a computer and processed.

Digital to analogue conversion is a process of turning a digital pattern from a computer into an analogue voltage or current.

## REVISION OF BINARY NUMBERS

A number may be represented in digital form by simply setting a pattern of voltages on a line high or low. It is normal to use 4, 8, 16 or 32 lines. An 8 bit binary pattern is shown below.

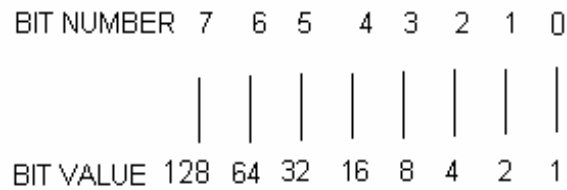

Figure 12

The total pattern is called a word and the one shown is an 8 bit word. The pattern may be stored in an 8 bit register. A register is a temporary store where the word may be manipulated.

Bit zero is called the least significant bit (LSB) and the bit with highest value is called the most significant bit (MSB).

Each bit has a value of zero when off (low) or the value shown when on (high). The maximum value for an 8 bit word is hence 255.

### SELF ASSESSMENT EXERCISE No.3

Write down the value of the digital number shown below.

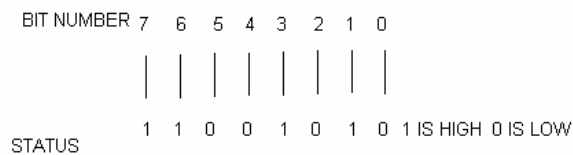

(Answer 202)

## PRINCIPLES OF A/D CONVERSION

### DIGITAL TO ANALOGUE CONVERTERS

These are devices for converting a binary number into an analogue voltage. The change in the binary value from zero to a maximum corresponds with a change in the analogue value from 0 to a maximum.

### RESOLUTION

When a digital number is converted into a voltage, each increment of the binary value corresponds with an increment in the voltage output. The value of this increment is the resolution.

#### WORKED EXAMPLE No.7

Determine the resolution of an 8 bit register converted into a voltage in the range 0 to 10 V. What is the digital value that represents a value of 4 Volts?

#### SOLUTION

Analogue Range = 0 - 10 V    Digital range = 0 – 255    Resolution =  $10/255 = 0.039216$   
4 volts would give a digital value of  $4 \div 0.039216 = 102$

### ADDER TYPE CONVERTER

One way to convert a digital pattern into an analogue voltage is with the adder type shown below. The diagram shows a 5 bit pattern.

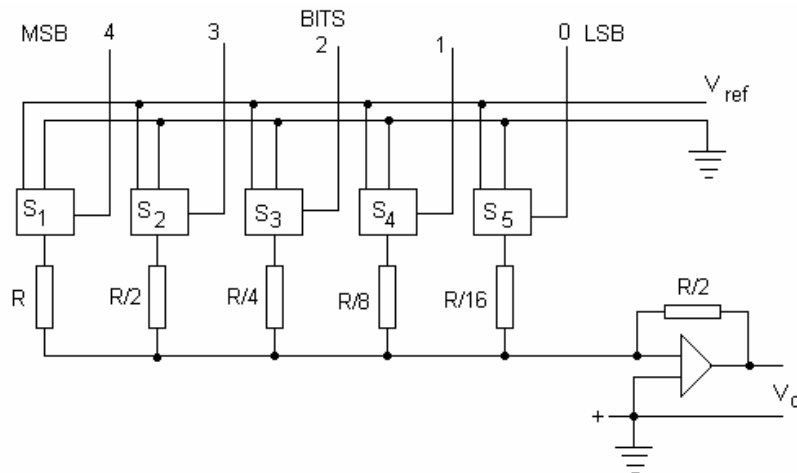

Figure 13

The output voltage is controlled by the state of the I/O switches (these might be a register). The output of the summing amplifier is

$$V_o = (V_{ref}/2)[1/16 + 1/8 + 1/4 + 1/2 + 1]$$

1/16 is the least significant bit and 1 is the most significant bit.

The maximum number represented by the digital number is 31 for the 5 bit system shown. An increase of one produces a voltage increment of  $1/32V$ . The maximum voltage output is  $31V/32$ .

One problem with this system is that the theoretical resistance values can become ridiculously large.

### WORKED EXAMPLE No. 8

If  $s_1$  and  $s_4$  are on and the others off and  $V_{ref} = 10$ , what is the voltage output?

### SOLUTION

$$V_o = (V/2)[1/16 + 1/8 + 1/4 + 1/2 + 1]$$

$$V_o = (10/2)[1/16 + 0 + 0 + 1/2 + 0]$$

$$V_o = 5[9/16] = 2.8125 \text{ V}$$

### SELF ASSESSMENT EXERCISE No.4

What is the incremental voltage for an 8 bit register with a reference of 10V? (Answer 1/128 V)

What is the voltage output when the digital value is 202? (Answer 3.242 V)

### LADDER TYPE

Another way to convert a digital signal into an analogue signal is with the ladder type illustrated below.

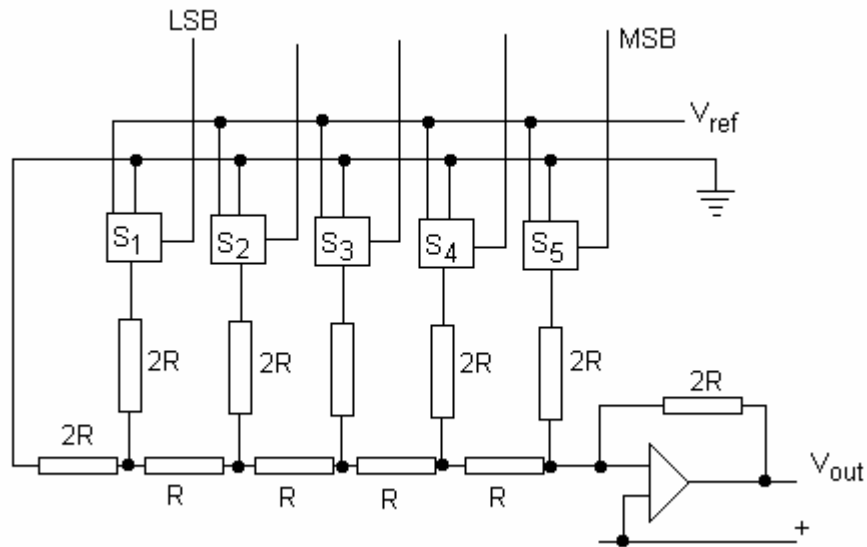

Figure 14

The output voltage is given by

$$V_o = (V_{ref}/2)[1/16 + 1/8 + 1/4 + 1/2 + 1]$$

## ANALOGUE TO DIGITAL CONVERSION

One way to convert analogue into digital is to utilise a counter as shown below.

### COUNTER TYPE

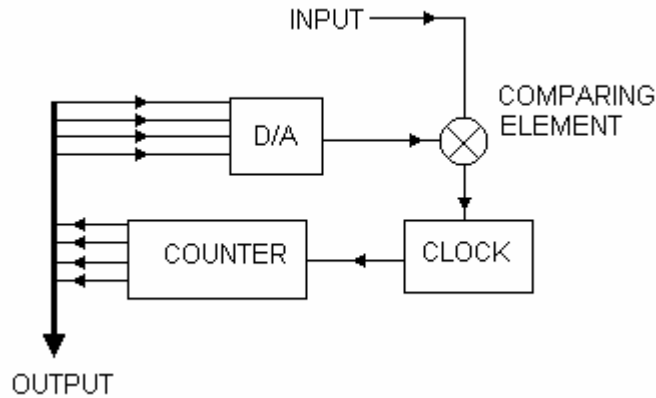

Figure 15

The output of the counter is a digital pattern and this is converted back into an analogue signal by the D/A converter and compared with the input. The input is compared with the feedback signal and so long as it is smaller, the counter will go on running. When the two become equal, the counter stops and the digital value of the counter is the digital value of the analogue signal.

Another type uses an integrator as shown

### INTEGRATING TYPE

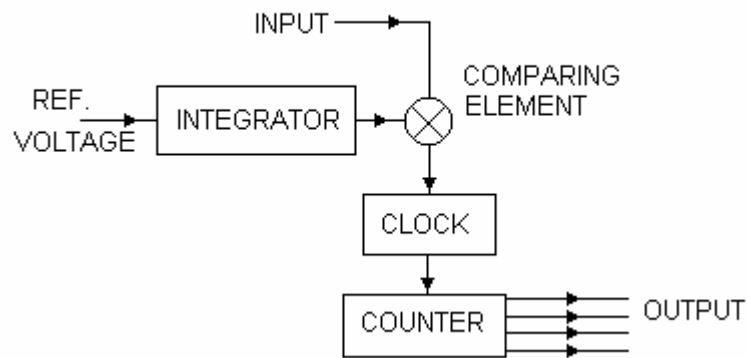

Figure 16

This time no feedback is used. The reference voltage is integrated so the output of the integrator is a ramp which grows with time. The time taken for the ramp to reach the same value as the input is converted into a digital form by a counter.

## 2.5 SIGNAL CONDITIONERS.

Now let's look at processors which change the characteristic of the signal. These are often referred to as SIGNAL CONDITIONERS. One example is the square root extractor. For example DP flow meters produce an output which is directly proportional to the square of the flow. A processor might be used along with the DP cell to extract the square root so that the resulting signal is directly proportional to flow.

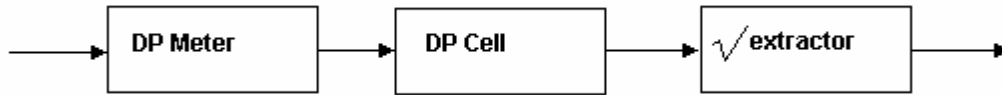

Figure 17

Other conditioners bring in the time element. For example the flow meter produces a signal representing the flow rate. If the signal is integrated with time, the output is quantity. Such a unit is called an INTEGRATOR and there are mechanical, pneumatic and electric methods.

Some meters produce a quantity. For example a movement transducer produces distance. If the signal is differentiated with respect to time, we get the rate or velocity. Such units are called DIFFERENTIATORS.

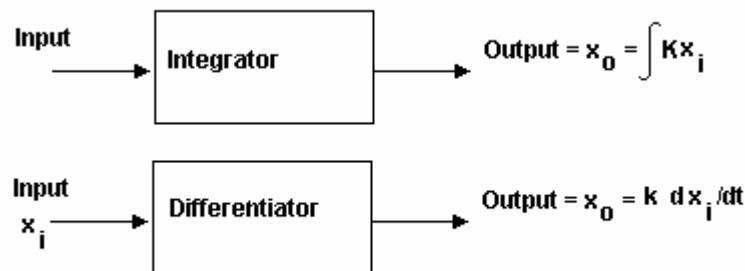

Figure 18

## FILTERS

Another form of signal conditioning is the SIGNAL FILTER. This is used with electric signals to remove unwanted parts of the signal. For example a signal may contain AC and DC signals. A simple capacitor would filter out the DC signal. The signal may contain AC signals of different frequencies. A more sophisticated filter would remove unwanted frequencies.

## MULTIPLEX SYSTEMS.

A modern industrial information transmission system requires that many channels be sent from one place to another using either a single frequency of transmission or a single pair of wires such as a telephone line. A system that does this is called multiplexing.

Modems are units that receive and transmit the information to each other. They require a marker signal to let each other know when to receive or transmit. The modem acknowledges a request to receive and this is called handshaking. When acknowledgement is received by the transmitting modem, it sends the data to the receiving modem.

The channels are sampled very rapidly one after another for a fixed period of time. This is called Time Division Multiplexing (TDM). Each sample is tacked in a queue (a buffer) and sent one after another. The process is continually repeated. The receiving end reverses the operation. The incoming data is placed in a buffer, extracted in sequence and diverted to the correct output.

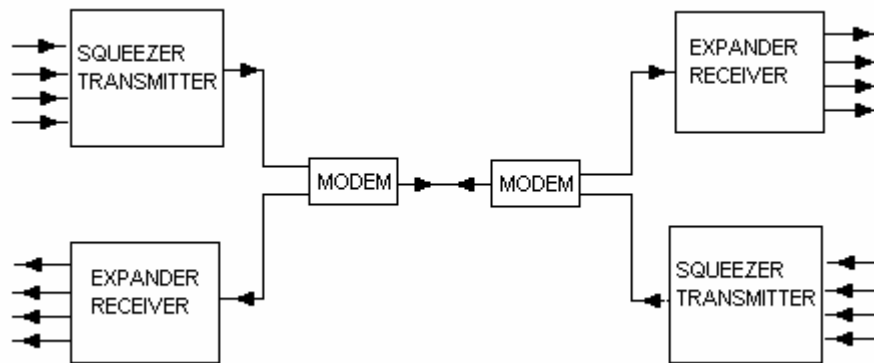

Figure 19

If the information is digital, it sends the information for each channel as a package of digits one channel at a time.

### BUFFERS and STORES

Very often a signal value needs to be stored. This is usually done by converting them into a digital number and storing them in a memory chip. If a system is receiving or sending serial data but the incoming data is arriving quicker than it can be processed, then the incoming signals are put into a temporary store called a buffer where they wait to be processed.

### 3. SIGNAL RECEIVERS

The input of an instrument system is sensed with a primary transducer and then processed or conditioned before being sent on to the last item in the chain which is the signal receiver. The signal receiver may be

- an indicator
- a chart recorder
- a plotter
- a printer
- an alarm
- a computer

Each of these is a complete system in its own right and may itself contain further conditioning. They are usually designed to operate from standard signals. In control systems, the signal receiver might be an actuator. This is covered in later tutorials on control.

#### INDICATORS

Indicators may be analogue or digital. Analogue indicators have a scale and a pointer moves along the scale to indicate the value. Digital indicators may be a display of numerals which change in fixed steps. Sometimes a digital indicator is made to simulate an analogue scale (e.g. a digital watch with hands). The pointer however moves in fixed steps. Digital indicators have a minimum resolution and usually this is smaller than the resolution a human eye can make on an analogue scale so digital indicators are often more accurate to read.

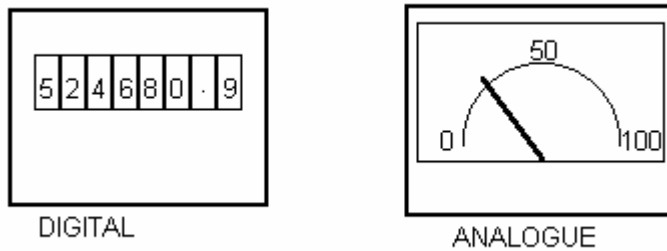

Figure 20

It is easier to make a mistake reading an analogue scale than a digital indicator. However when the value indicated is changing rapidly, an analogue indication is best because you can see the way the pointer is moving. It would be difficult to read a rapidly changing set of numerals. For example, speedometer and altimeters are best displayed on an analogue scale.

#### CHART RECORDERS

Chart recorders keep a record of the measurements over a period of time. There are electrical and pneumatic versions. The recorder may use paper strips or polar charts. The paper moves one way and the marker pen moves at right angles to this. Often they use more than one pen to record several channels. The recorder is often part of a controlled system and contains other equipment to do with the control.

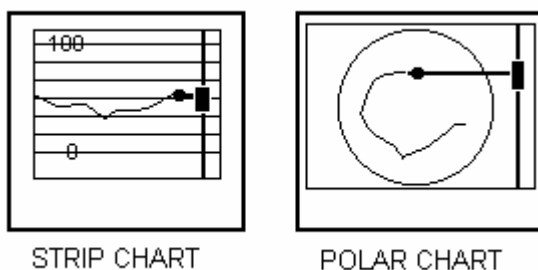

Figure 21

Paper recorders are being replaced by computer systems which store the information on a magnetic medium and displays either the indicated reading or the chart record or both on a visual display unit (computer screen or VDU).

## PLOTTERS AND PRINTERS

Plotters draw graphs or charts. The pen recorders described above are types of plotters specifically for recording a signal over a long time period. The term plotter usually refers to a system where the paper is stationary and the pen is able to move in the x and y directions. Often the x direction is time and so the plotter become a recorder. Plotters are more often used to plot one signal against another. They are very commonly used for producing engineering drawings created on a computer.

Printers refer to a system where the paper is marked by a printing head. There are many types such as dot matrix, ink jets, laser and other electrostatic devices. Printers will print text or they may be used to print pictures and drawings reproducing on paper what can be seen on a VDU.

## ALARMS

The purpose of an instrument may be to set off an alarm such as a bell, siren, flashing light and so on. They are switched on by the signal processor. An example is a smoke detector.

## COMPUTERS

Computer technology is taking over many rolls performed by traditional equipment. The signal is processed into digital form, in other words into numbers. The computer processes the numbers and stores the data, sends it on to a VDU or to other control equipment.