

# INSTRUMENTATION AND CONTROL

## TUTORIAL 2 – SENSORS AND PRIMARY TRANSDUCERS

This tutorial provides an overview of instrument sensors used in process and automatic control. It is useful to anyone studying measurement systems and instrumentation but it is provided mainly in support of the EC module D227 – Control System Engineering. This tutorial is mainly descriptive.

Control is a broad concept and the following might apply to an automated system such as a robot or to a process control system such as a pneumatic valve controlling the flow of steam in a pipe.

On completion of this tutorial, you should be able to do the following.

- Explain a basic measurement system.
- Explain the basic working principles of a variety of temperature sensors.
- Explain the basic working principles of a variety of pressure sensors.
- Explain the basic working principles of a variety of speed transducers.
- Explain the basic working principles of a variety of flow meters.
- Explain the basic working principles of a variety of force gauges.
- Explain the basic working principles of a variety of displacement gauges.
- Explain the basic working principles of a variety of level (depth) gauges.
- Explain in some detail the theory and use of strain gauges.

In order to complete the theoretical part of this tutorial, you must be familiar with basic mechanical and electrical science.

# 1. INTRODUCTION

A basic instrument system consists of three elements:

- i SENSOR or INPUT DEVICE
- ii SIGNAL PROCESSOR
- iii RECEIVER or OUTPUT DEVICE

This tutorial is devoted to input devices but you can never separate it from the rest of the system as in many cases they are all integral (e.g. a mechanical pressure gauge incorporates all of these elements). A block diagram of a basic system is shown but they are usually more complex.

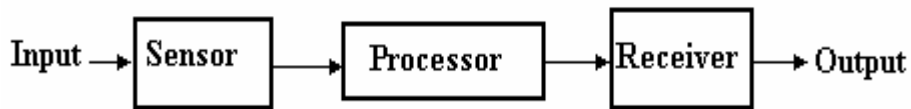

Figure 1

Most modern analogue equipment works on the following standard signal ranges.

- Electric 4 to 20 mA
- Pneumatic 0.2 to 1.0 bar

Older electrical equipment use 0 to 10 V. Increasingly the instruments are digital with a binary digital encoder built in to give a binary digital output. Pneumatic signals are commonly used in process industries for safety especially when there is a risk of fire or explosion.

The advantage of having a standard range or using digital signals is that all equipment may be purchased ready calibrated. For analogue systems the minimum signal (Temperature, speed, force, pressure and so on ) is represented by 4 mA or 0.2 bar and the maximum signal is represented by 20 mA or 1.0 bar.

This tutorial is an attempt to familiarise you with the many types of input sensors on the market today. Usually such sensors are called PRIMARY TRANSDUCERS.

Things that we commonly measure are:

**Temperature**

**Speed**

**Force**

**Stress and Strain**

**Mass or Weight**

**Size or Volume**

**Pressure**

**Flow rate**

**Movement, Velocity and Acceleration**

**Level or Depth**

**Density**

**Acidity/Alkalinity**

Sensors may operate simple on/off switches to detect the following:

**Objects(Proximity switch)**

**Hot or cold (thermostat)**

**Empty or full (level switch)**

**Pressure high or low (pressure switch)**

The block diagram of a sensor is shown below.

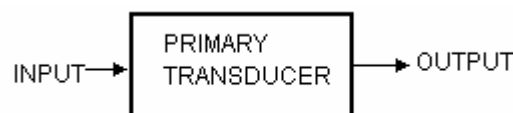

Figure 2

## 2 TEMPERATURE TRANSDUCERS

### 2.1 THERMOCOUPLES

When two wires with dissimilar electrical properties are joined at both ends and one junction is made hot and the other cold, a small electric current is produced proportional to the difference in the temperature. Seebeck discovered this effect. It is true no matter how the ends are joined so the cold end may be joined at a sensitive millivolt meter. The hot junction forms the sensor end.

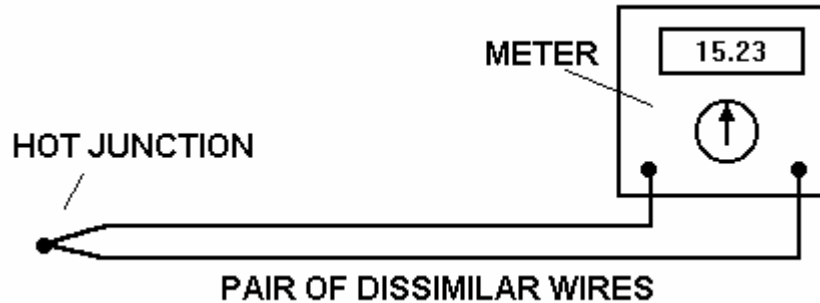

Figure 3

The picture shows a typical industrial probe with a flexible extension and standard plug.



Figure 4

Peltier showed that heat is absorbed at the hot end and rejected at the cold end. Thompson showed that part of the e.m.f. is due to the temperature gradient in the wire as well as the temperature difference between the junctions. Most thermocouple metals produce a relationship between the two temperatures and the e.m.f as follows.

$$e = \alpha(\theta_1 - \theta_2) + \beta(\theta_1^2 - \theta_2^2)$$

$\alpha$  and  $\beta$  are constants for the type of thermocouple. The relationship is nearly linear over the operating range. The actual characteristic and suitable operating temperatures depends upon the metals used in the wires. The various types are designated in international and national standards. Typical linear operating ranges are shown for standard types.

It is important that thermocouples are standard so that the same e.m.f will always represent the same temperature.

Type J	0 to 800°C
Type K	0 to 1200°C
Type T	-199 to 250°C
Type E	0 to 600°C
Type R/S	0 to 1600°C
Type B	500 to 1800°C
Type N	0 to 1200°C
Type L	0 to 800°C

Thermocouples come in several forms. They may be wires insulated from each other with plastic or glass fibre materials. For high temperature work, the wire pairs are put inside a tube with mineral insulation. For industrial uses the sensor comes in a metal enclosure such as stainless steel.

## 2.2 RESISTANCE TYPE SENSORS

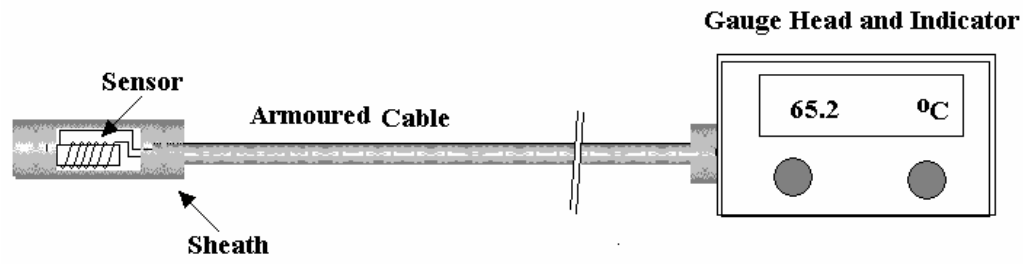

Figure 5

These work on the principle that the electrical resistance of a conductor change with temperature. If a constant voltage is applied to the conductor then the current flowing through it will change with temperature. The resistivity of the conductor change with temperature. This usually means the resistance gets bigger as the conductor gets hotter. The following law relates the resistance and temperature.

$$R = R_0(1 + \alpha\theta)$$

$\alpha$  is the temperature coefficient of resistance.  $R_0$  is the resistance at 0°C. Sometimes the equation is given as

$$R = R_0(1 - \alpha\theta - \beta\theta^2)$$

A basic temperature sensor is made by winding a thin resistance wire into a small sensor head. The resistance of the wire then represents the temperature. This has an advantage over a thermocouple in that it is unaffected by the temperature of the gauge end. The main type of wire used is **PLATINUM**. The sensors are usually manufactured to have a resistance of 100  $\Omega$  at 0°C and the value of  $\alpha$  is 0.00385 to 0.00390. A typical operating range is -200 to 400°C.

A special type of resistance sensor is called a **THERMISTOR**. They are made from a small piece of semi-conductor material. The material is special because the resistance changes a lot for a small change in temperature and so can be made into a small sensor and it costs less than platinum wire. The temperature range is limited. They are only used for a typical range of -20 to 120°C and are commonly used in small hand held thermometers for every day use. The relationship between resistance and temperature is of the form  $R = Ae^{B/\theta}$

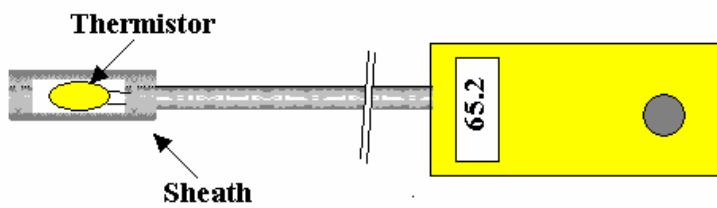

### **WORKED EXAMPLE No.1**

A Platinum resistance thermometer has a resistance of 100  $\Omega$  at 0°C and the value of  $\alpha$  is 0.00385. In operation the resistance is 101  $\Omega$ . Calculate the temperature.

### **SOLUTION**

Rearrange the formula to make  $\theta$  the subject and evaluate.

$$? = \frac{\frac{R}{R_0} - 1}{\alpha} = \frac{\frac{101}{100} - 1}{0.00385} = 12.987^\circ\text{C}$$

### **WORKED EXAMPLE No.2**

A thermocouple produces an e.m.f. in mV according to the temperature difference between the sensor tip  $\theta_1$  and the gauge head  $\theta_2$  such that

$$e = \alpha(\theta_1 - \theta_2) + \beta(\theta_1^2 - \theta_2^2)$$

$\alpha = 3.5 \times 10^{-2}$  and  $\beta = 8.2 \times 10^{-6}$  The gauge head is at 20°C. The mV output is 12 mV. Calculate the temperature at the sensor.

### **SOLUTION**

$$10 = 0.035(\theta_1 - 20) + 8.2 \times 10^{-6}(\theta_1^2 - 20^2)$$

$$10 = 0.035\theta_1 - 0.7 + 8.2 \times 10^{-6}\theta_1^2 - 0.00328$$

$$10 = 8.2 \times 10^{-6}\theta_1^2 + 0.035\theta_1 - 0.69672$$

$$8.2 \times 10^{-6}\theta_1^2 + 0.035\theta_1 - 9.30328 = 0$$

Solving the quadratic equation yields  $\theta_1 = 251^\circ\text{C}$

### **SELF ASSESSMENT EXERCISE No.1**

1. A thermocouple produces an e.m.f. in mV according to the temperature difference between the sensor tip  $\theta_1$  and the gauge head  $\theta_2$  such that  $e = \alpha(\theta_1 - \theta_2) + \beta(\theta_1^2 - \theta_2^2)$   
Given  $\alpha = 3.5 \times 10^{-2}$  and  $\beta = 8.2 \times 10^{-6}$  determine the mV output when the tip is at 220°C and the gauge head at 20°C.  
**(Answer 7.394 mV)**
2. Describe the basic construction of a resistance type temperature sensor and state the reason why it is unaffected by the temperature of the gauge head.
3. State two reasons why instrument systems use standard transmission signal of either 4 - 20 mA or 0.2 - 1 bar.

### 2.3 LIQUID EXPANSION and VAPOUR PRESSURE SENSORS

These are thermometers filled with either a liquid such as mercury or an evaporating fluid such as used in refrigerators. In both cases the inside of the sensor head and the connecting tube are completely full. Any rise in temperature produces expansion or evaporation of the liquid so the sensor becomes pressurised. The pressure is related to the temperature and it may be indicated on a simple pressure gauge.

Ways and means exist to convert the pressure into an electrical signal. The movement may also directly operate a thermostat. These instruments are robust and used over a wide range. They can be fitted with electric switches to set off alarms.



Figure 6

### 2.4 BIMETALLIC TYPES

It is a well-known principle that if two metals are rigidly joined together as a two-layer strip and heated, the difference in the expansion rate causes the strip to bend.



Figure 7

In the industrial type, the strip is twisted into a long thin coil inside a tube. One end is fixed at the bottom of the tube and the other turns and moves a pointer on a dial. The outward appearance is very similar to the pressure type. They can be made to operate limit switches and set off alarms or act as a thermostat. (e.g. on a boiler).

## 2.5 GLASS THERMOMETER

The ordinary glass thermometer is also a complete system. Again the bulb is the sensor but the column of liquid and the scale on the glass is the processor and indicator. Mercury is used for hot temperatures and coloured alcohol for cold temperatures.



Figure 8

The problems with glass thermometers are that they are

- Brittle
- Mercury solidifies at  $-40^{\circ}\text{C}$ .
- Alcohol boils at around  $120^{\circ}\text{C}$ .
- Accurate manufacture is needed and this makes accurate ones expensive.
- It is easy for people to make mistakes reading them.

Glass thermometers are not used much now in industry but if they are, they are usually protected by a shield from accidental breakage. In order to measure the temperature of something inside a pipe they are placed in thermometer pockets.

### 3. PRESSURE TRANSDUCERS

Pressure sensors either convert the pressure into mechanical movement or into an electrical output. Complete gauges not only sense the pressure but indicate them on a dial or scale.

Mechanical movement is produced with the following elements.

- Bourdon Tube.
- Spring and Piston.
- Bellows and capsules.
- Diaphragm.

#### 3.1. BOURDON TUBE

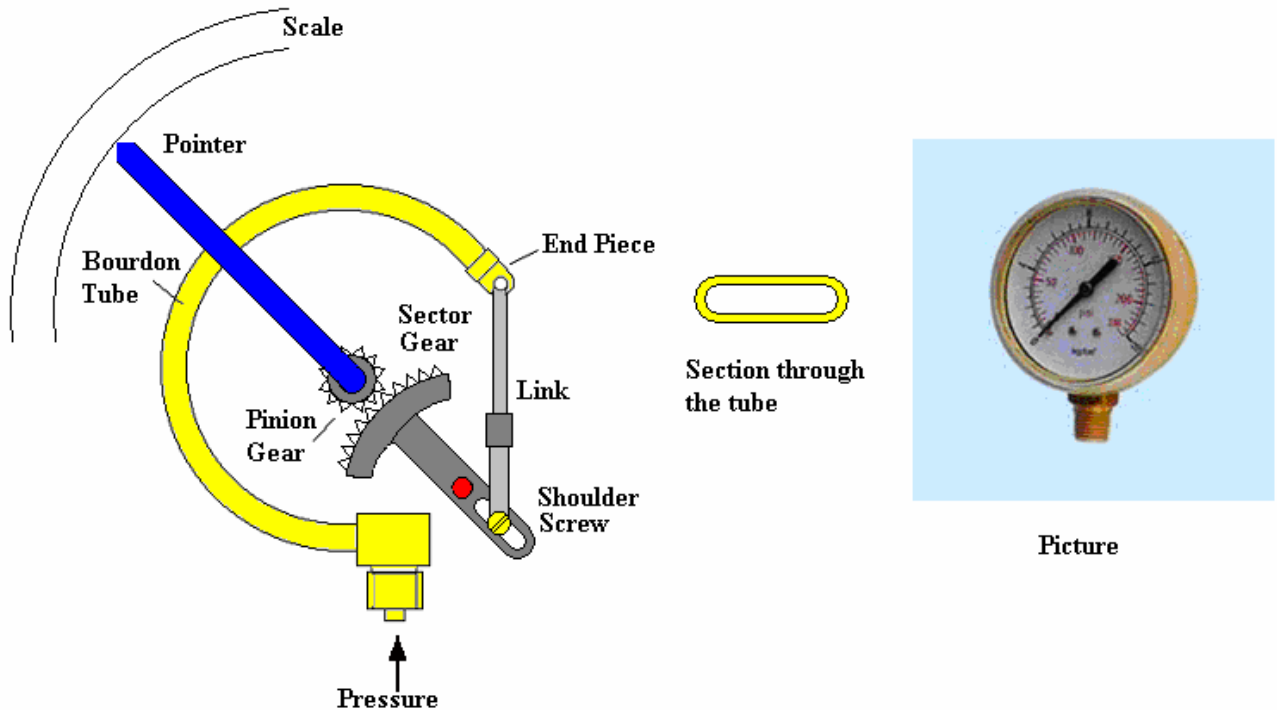

Figure 9

The Bourdon tube is a hollow tube with an elliptical cross section. When a pressure difference exists between the inside and outside, the tube tends to straighten out and the end moves. The movement is usually coupled to a needle on a dial to make a complete gauge. It can also be connected to a secondary device such as an air nozzle to control air pressure or to a suitable transducer to convert it into an electric signal. This type can be used for measuring pressure difference.

### 3.2 PISTON TYPE

The pressure acts directly on the piston and compresses the spring. The position of the piston is directly related to the pressure. A window in the outer case allows the pressure to be indicated. This type is usually used in hydraulics where the ability to withstand shock, vibration and sudden pressure changes is needed (shock proof gauge). The piston movement may be connected to a secondary device to convert movement into an electrical signal.

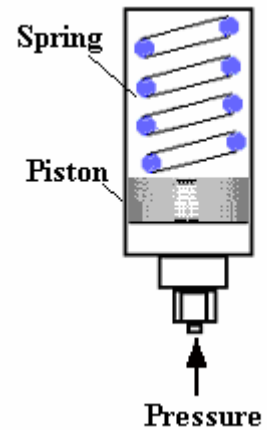

Figure 10

### 3.3. CAPSULES AND BELLOWS

A bellows is made of several capsules. These are hollow flattened structures made from thin metal plate. When pressurised the bellows expand and produce mechanical movement. If the bellows is encapsulated inside an outer container, then the movement is proportional to the difference between the pressure on the inside and outside. Bellows and single capsules are used in many instruments. They are very useful for measuring small pressures.

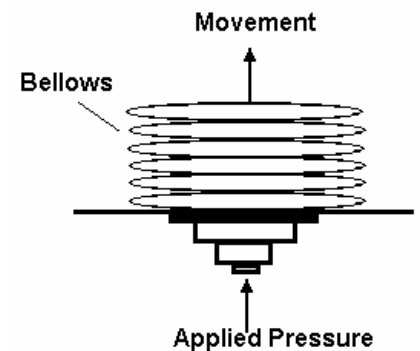

Figure 11

### 3.4 DIAPHRAGMS

These are similar in principle to the capsule but the diaphragm is usually very thin and perhaps made of rubber. The diaphragm expands when very small pressures are applied. The movement is transmitted to a pointer on a dial through a fine mechanical linkage.

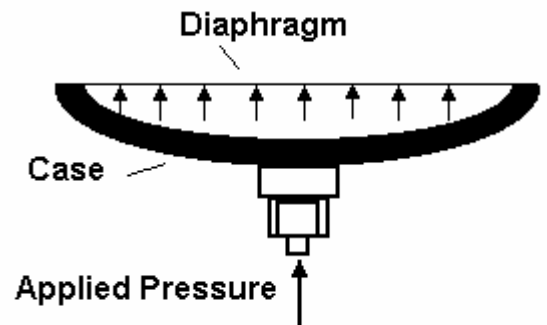

Figure 12

### 3.5 ELECTRICAL PRESSURE TRANSDUCERS

There are various ways of converting the mechanical movement of the preceding types into an electric signal. The following are types that directly produce an electric signal.

- Strain Gauge types.
- Piezo electric types.
- Other electric effects.

### 3.5.1 STRAIN GAUGE TYPES

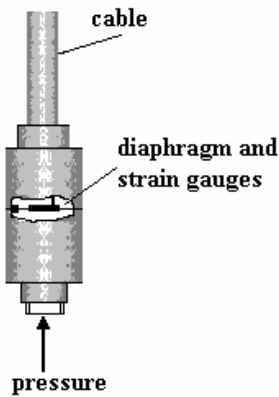

Figure 13

The principles of electric strain gauges are covered later. Strain gauges are small elements that are fixed to a surface that is strained. The change in length of the element produces changes in the electrical resistance. This is processed and converted into a voltage. A typical pressure transducer would contain a metal diaphragm which bends under pressure.

### 3.5.2. PIEZO ELECTRIC TYPES

The element used here is a piece of crystalline material that produces an electric charge on its surface when it is mechanically stressed. The electric charge may be converted into voltage. This principle is used in the pick up crystal of a record player, in microphones and even to generate a spark in a gas ignitor. When placed inside a pressure transducer, the pressure is converted into an electric signal.

### 3.5.3. OTHER ELECTRIC EFFECTS

Other electric effects commonly used in transducers are CAPACITIVE and INDUCTIVE. In these cases, the pressure produces a change in the capacitance or inductance of an electronic component in the transducer. Both these effects are commonly used in an electronic oscillator and one way they may be used is to change the frequency of the oscillation. The frequency may be converted into a voltage representing the pressure.

## 4. SPEED TRANSDUCERS

Speed transducers are widely used for measuring the output speed of a rotating object. There are many types using different principles and most of them produce an electrical output.

### 4.1 OPTICAL TYPES

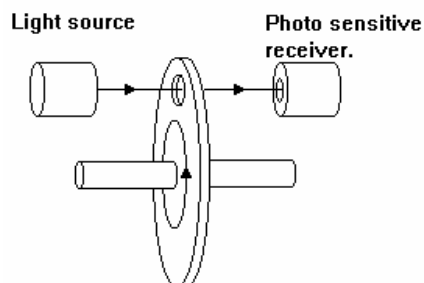

Figure 14

These use a light beam and a light sensitive cell. The beam is either reflected or interrupted so that pulses are produced for each revolution. The pulses are then counted over a fixed time and the speed obtained. Electronic processing is required to time the pulses and turn the result into an analogue or digital signal.

## 4.2 MAGNETIC PICK UPS

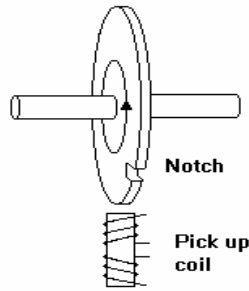

Figure 15

These use an inductive coil placed near to the rotating body. A small magnet on the body generates a pulse every time it passes the coil. If the body is made of ferrous material, it will work without a magnet. A discontinuity in the surface such as a notch will cause a change in the magnetic field and generate a pulse. The pulses must be processed to produce an analogue or digital output.

## 4.3 TACHOMETERS

There are two types, A.C. and D.C. The A.C. type generates a sinusoidal output. The frequency of the voltage represents the speed of rotation. The frequency must be counted and processed. The D.C. type generates a voltage directly proportional to the speed. Both types must be coupled to the rotating body. very often the tachometer is built into electric motors to measure their speed.



Figure 16

## 5. FLOW METERS

There are many hundreds of types of flow meters depending on the make and application. They may be classified roughly as follows.

- POSITIVE DISPLACEMENT TYPES
- INFERENCEAL TYPES
- VARIABLE AREA TYPES
- DIFFERENTIAL PRESSURE TYPES

### 5.1. POSITIVE DISPLACEMENT TYPES

These types have a mechanical element that makes the shaft of the meter rotate once for an exact known quantity of fluid. The quantity of fluid hence depends on the number of revolutions of the meter shaft and the flow rate depends upon the speed of rotation. Both the revolutions and speed may be measured with mechanical or electronic devices. Some of the most common listed below.

- Rotary piston type.
- Vane type.
- Lobe type or meshing rotor.
- Reciprocating piston type
- Fluted spiral gear.

#### 5.1.1 MESHING ROTOR

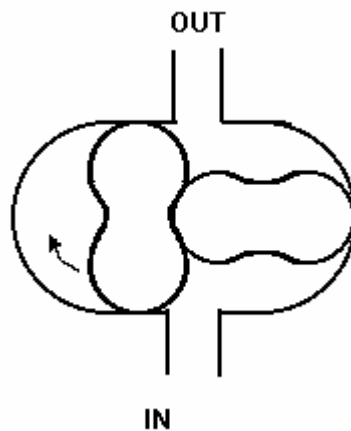

Figure 17

The MESHING ROTOR type consists of two rotors with lobes. When fluid is forced in, the rotors turn and operate the indicating system.

### 5.2. INFERENCEAL TYPE METERS

The flow of the fluid is inferred from some effect produced by the flow. Usually this is a rotor which is made to spin and the speed of the rotor is sensed mechanically or electronically. The main types are :

- Turbine rotor types
- Rotary shunt types
- Rotating vane types
- Helical turbine types

### 5.2.1 TURBINE TYPE

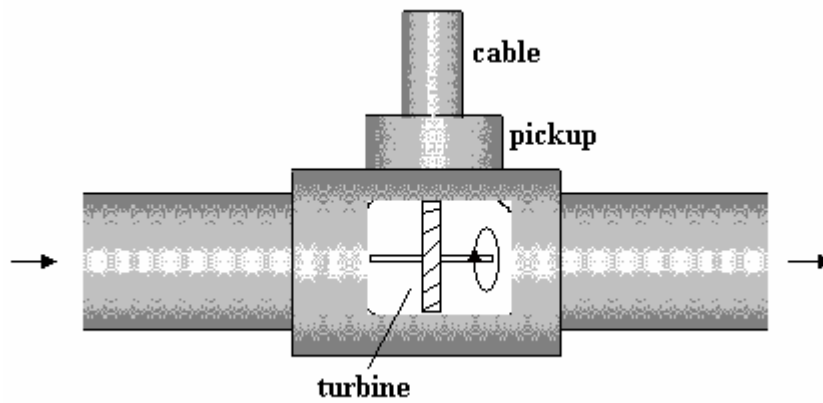

Figure 18

The pictures show two industrial flow meters.



Figure 19

The turbine type shown has an axial rotor which is made to spin by the fluid and the speed represents the flow rate. This may be sensed electrically by coupling the shaft to a small electric tachometer. Often this consists of a magnetic slug on the rotor which generates a pulse of electricity each time it passes the sensor.

### 5.2.2 ROTATING VANE TYPE



Figure 20

The jet of fluid spins around the rotating vane and the speed of the rotor is measured mechanically or electronically.

### 5.3.3. VARIABLE AREA TYPES

There are two main types of this meter

- Float type (Rotameter)
- Tapered plug type.

#### 5.3.3.1 FLOAT TYPE

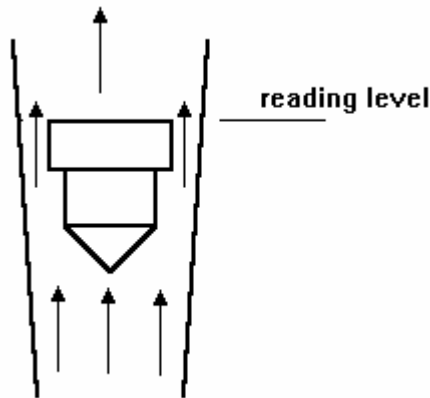

Figure 21

The float is inside a tapered tube. The fluid flows through the annular gap around the edge of the float. The restriction causes a pressure drop over the float and the pressure forces the float upwards. Because the tube is tapered, the restriction is decreased as the float moves up. Eventually a level is reached where the restriction is just right to produce a pressure force that counteracts the weight of the float. The level of the float indicates the flow rate. If the flow changes the float moves up or down to find a new balance position.

When dangerous fluids are used, protection is needed against the tube fracturing. The tube may be made of a non-magnetic metal. The float has a magnet on it. As it moves up and down, the magnet moves a follower and pointer on the outside. The position of the float may be measured electrically by building a movement transducer into the float.

#### 5.3.3.2 TAPERED PLUG TYPE.

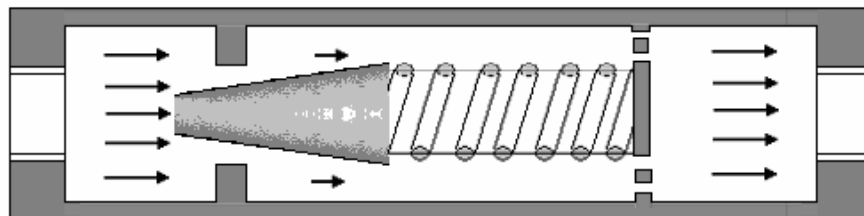

Figure 22

In this meter, a tapered plug is aligned inside a hole or orifice. A spring holds it in place. The flow is restricted as it passes through the gap and a force is produced which moves the plug. Because it is tapered the restriction changes and the plug takes up a position where the pressure force just balances the spring force. The movement of the plug is transmitted with a magnet to an indicator on the outside.

## 5.4 DIFFERENTIAL PRESSURE FLOW METERS

These are a range of meters that convert flow rate into a differential pressure. The important types conform to BS 1042 and are

- ORIFICE METERS.
- VENTURI METERS
- NOZZLE METERS
- PITOT TUBES.

The diagram shows a cross section through the four types of d.p. meters.

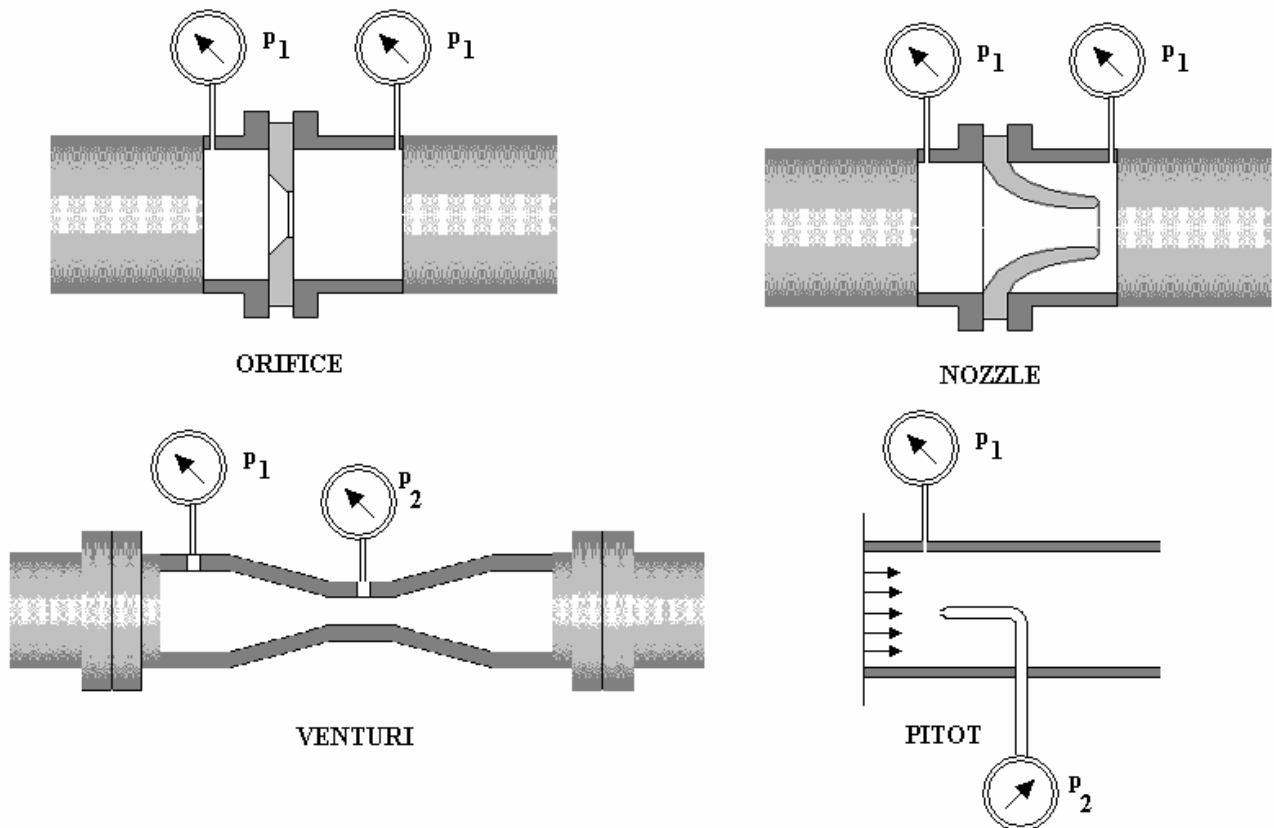

Figure 23

The working principle for all these is that something makes the velocity of the fluid change and this produces a change in the pressure so that a difference  $\Delta p = p_2 - p_1$  is created. It can be shown for all these meters that the volume flow rate  $Q$  is related to  $\Delta p$  by the following formula.

$$Q = K(Dp)^{0.5}$$

$K$  is the meter constant. A full explanation of these meters is covered in the tutorials on fluid mechanics. The picture shows an industrial d.p. meter. Extra instrumentation heads can be fitted to produce an electrical output (4 – 20 mA) or a pneumatic output (0.2 – 1 bar).



Figure 24

### **WORKED EXAMPLE No.3**

A Venturi meter has a meter constant of  $0.008 \text{ m}^4 \text{ N}^{-0.5} \text{ s}^{-1}$ . Calculate the flow rate when  $\Delta p = 180 \text{ Pa}$

### **SOLUTION**

$$Q = K(\Delta p)^{0.5} = 0.008 \text{ m}^4 \text{ N}^{-0.5} \text{ s}^{-1} (180)^{0.5} = 0.1073 \text{ (m}^4 \text{ N}^{-0.5} \text{ s}^{-1}) (\text{N}^{0.5} \text{ m}^{-1}) \text{ or m}^3/\text{s}$$

### **SELF ASSESSMENT EXERCISE No.2**

An Orifice meter has a meter constant of  $0.004 \text{ m}^4 \text{ N}^{-0.5} \text{ s}^{-1}$ . Calculate the flow rate when a differential pressure of 200 Pa is obtained.

(Answer  $0.0566 \text{ m}^3/\text{s}$ )

## 6. FORCE SENSORS

The main types of force sensors are

- Mechanical types.
- Hydraulic types.
- Electrical strain gauge types.

### 6.1. MECHANICAL TYPES

Mechanical types are usually complete measuring systems involving some form of spring such as in a simple spring balance or bathroom scale. It is a basic mechanical principle that the deflection of a spring is directly proportional to the applied force so if the movement is shown on a scale, the scale represents force.

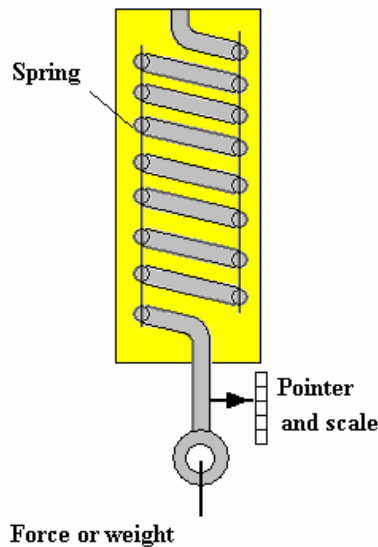

Figure 25

### 6.2. HYDRAULIC TYPES

Hydraulic types are often referred to as hydraulic load cells. The cell is a capsule filled with liquid. When the capsule is squeezed, the liquid becomes pressurised. The pressure represents the force and may be indicated with a calibrated pressure gauge. The capsule is often a short cylinder with a piston and the pressure produced is given by  $p = F/A$  where  $F$  is the force and  $A$  the piston area.

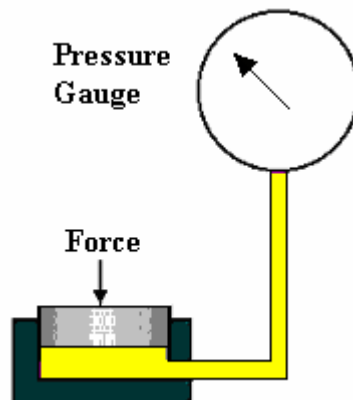

Figure 26

### 6.3 STRAIN GAUGE TYPE

A typical load cell consists of a metal cylinder with strain gauges fixed to it. When the cylinder is stretched or compressed, the strain gauges convert the force into a change in resistance and hence voltage. Since the elements require a supply voltage, the cell usually has 4 wires, two for the supply and two for the output.

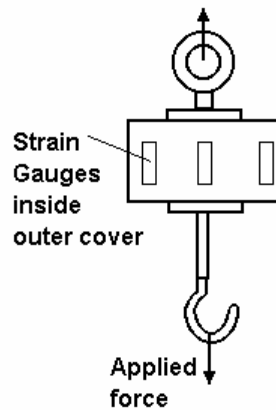

Figure 27

## 7. POSITION SENSORS

Position sensors are essential elements in the control of actuators. The position of both linear and rotary actuators is needed in robotic type mechanisms. There are three principle types.

- RESISTIVE
- OPTICAL
- INDUCTIVE

### 7.1. RESISTIVE TYPES

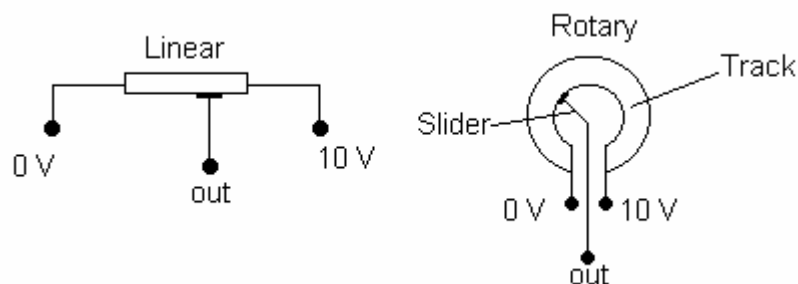

Figure 28

A potentiometer is a variable electrical resistance. A length of resistance material has a voltage applied over its ends. A slider moves along it (either linear or rotary) and picks off the voltage at its position or angle. The tracks may be made from carbon, resistance wire or piezo resistive material. The latter is the best because it gives a good analogue output. The wire wound type produces small step changes in the output depending on how fine the wire is and how closely it is coiled on the track.

## 7.2 OPTICAL TYPES

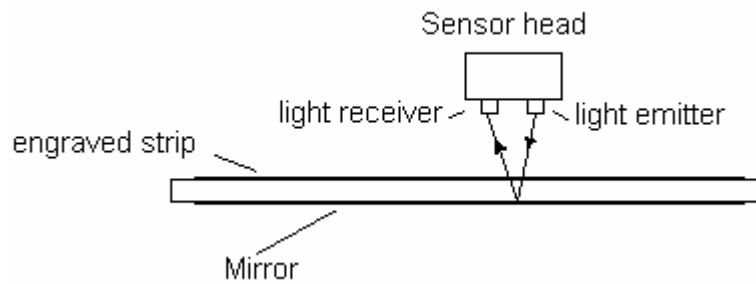

Figure 29

Optical types are mainly used for producing digital outputs. A common example is found on machine tools where they measure the position of the work table and display it in digits on the gauge head. Digital micrometers and verniers also use this idea. The basic principle is as follows. Light is emitted through a transparent strip or disc onto a photo electric cell. Often reflected light is used as shown. The strip or disc has very fine lines engraved on it which interrupt the beam. The number of interruptions are counted electronically and this represents the position or angle. This is very much over simplified and you should refer to more advanced text to find out how very accurate measurements are obtained and also the direction of movement.

## 7.3. INDUCTIVE TYPES

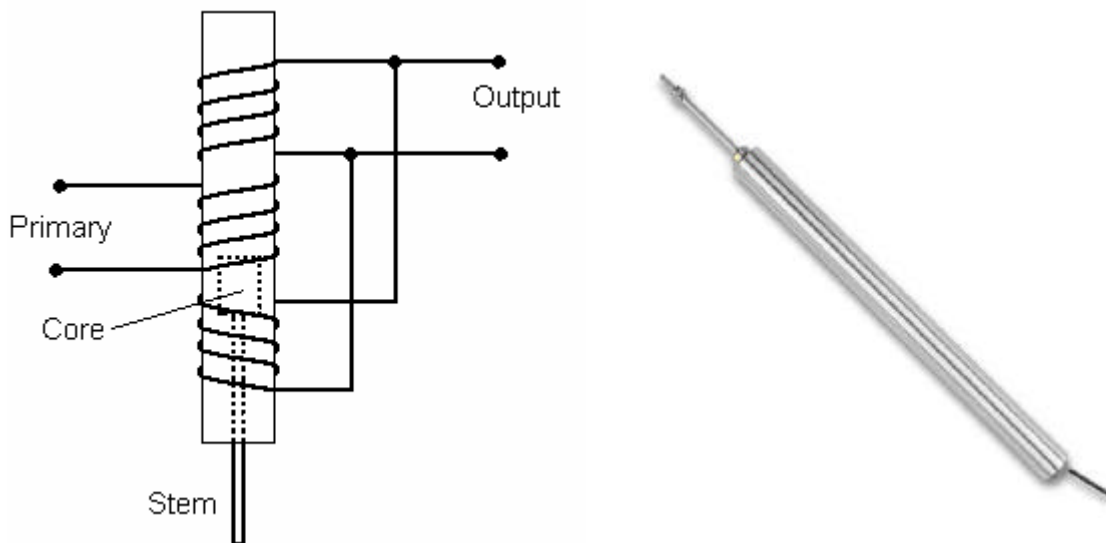

Figure 30

The most common of these is the Linear Variable Differential transformer or LVDT. The transformer is made with one primary coil and two secondary coils, one placed above and the other below the primary. The coils are formed into a long narrow hollow tube. A magnetic core slides in the tube and is attached to the mechanism being monitored with a non magnetic stem (e.g. brass). A constant alternating voltage is applied to the primary coil. This induces a voltage in both secondary coils. When the core is exactly in the middle, equal voltages are induced and when connected as shown, they cancel each other out. When the core moves, the voltage in one secondary coil grows but reduces in the other. The result is an output voltage which represents the position of the core and hence the mechanism to which it is attached. The output voltage is usually converted into D.C. With suitable electronic equipment for phase detection, it is possible to detect which direction the core moves and to switch the DC voltage from plus to minus as the core passes the centre position. These can be very accurate and are widely used for gauging the dimensions of machined components.

## 8. DEPTH GAUGES

Depth gauges measure the depth of liquids and powder in tanks. They use a variety of principles and produce outputs in electrical and pneumatic forms. The type to use depends on the substance in the tank. Here are a few.

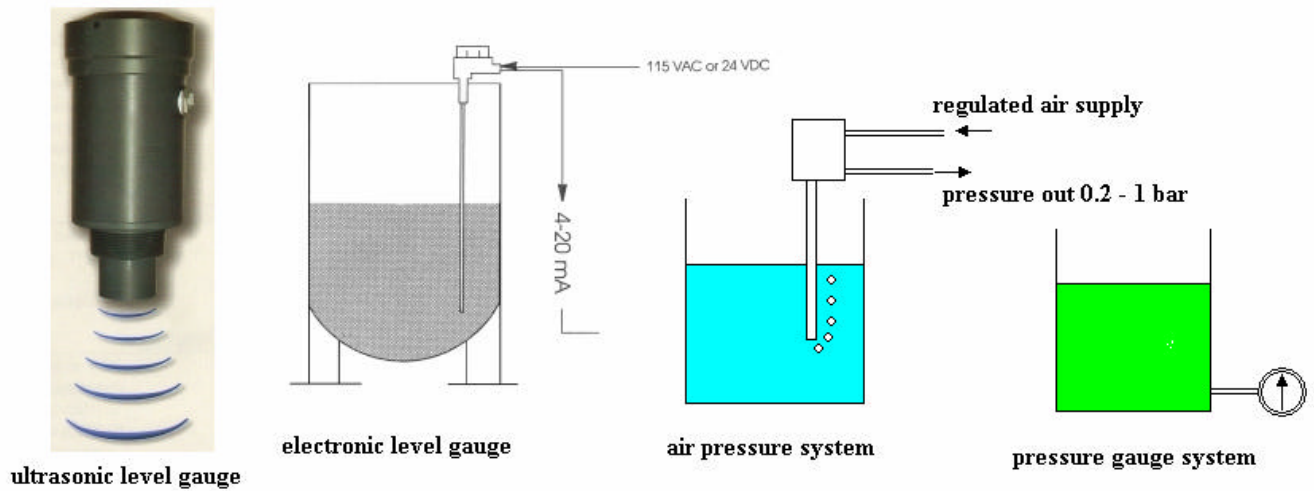

Figure 31

The ultrasonic system reflects sound waves from the surface and determines the depth from the time taken to receive the reflected sound. The electronic version uses a variety of electrical affects including conduction of the fluid and capacitance. The pneumatic version bubbles air through the liquid and the pressure of the air is related to the depth. A simple pressure gauge attached to a tank is also indicates the depth since depth is proportional to pressure.

## 9. STRAIN GAUGES

Strain gauges are used in many instruments that produce mechanical strain because of the affect being measured. In their own right, they are used to measure the strain in a structure being stretched or compressed.

The strain gauge element is a very thin wire that is formed into the shape shown. This produces a long wire all in one direction but on a small surface area. The element is often formed by etching a thin foil on a plastic backing. The completed element is then glued to the surface of the material or component that will be strained. The axis of the strain gauge is aligned with the direction of the strain. When the component is stretched or compressed, the length of the resistance wire is changed. This produces a corresponding change in the electrical resistance.

Let the length of the gauge be  $L$  and the change in length be  $\Delta L$ .

The mechanical strain  $\epsilon = \Delta L/L$

Let the resistance of the gauge be  $R$  (typically  $120 \Omega$ ) and the change in resistance be  $\Delta R$ .

The electrical strain  $\xi = \Delta R/R$ .

The electrical and mechanical strain are directly proportional and the constant relating them is called the gauge factor (typically 2).

Gauge Factor = Electrical Strain/Mechanical strain =  $\xi/\epsilon = L \Delta R/R \Delta L$

### WORKED EXAMPLE No.4

A strain gauge is glued to a structure. It has a gauge factor of 2.1 and a resistance of  $120.2 \Omega$ . The structure is stressed and the resistance changes to  $120.25 \Omega$ . Calculate the strain and convert this into stress.  
Take  $E = 205 \text{ GPa}$

### SOLUTION

$$\Delta R = 120.25 - 120.2 = 0.05 \Omega \quad \xi = \Delta R/R_1 = 0.05/120.2 = 4.16 \times 10^{-4}$$

$$\epsilon = \xi/G = 4.16 \times 10^{-4}/2.1 = 1.981 \times 10^{-4} \quad \sigma = \epsilon E = 1.981 \times 10^{-4} \times 205 \times 10^9 = 40.61 \text{ MPa}$$

## STRAIN GAUGE ARRANGEMENTS

A strain gauge is of little use unless we can convert the change in resistance into a voltage. This is best done with a Wheatstone bridge.

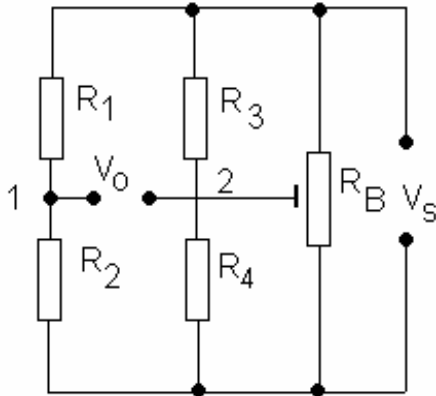

Figure 32

If only one active gauge is used, this would be  $R_1$  or  $R_2$ .  $R_1$  and  $R_2$  must be equal, so must  $R_3$  and  $R_4$ . In this case, the voltage at points 1 and 2 are equal to  $V_s/2$  and so the output  $V_o$  is zero. In order to ensure this, the balancing resistor  $R_B$  is adjusted to make the output zero with no strain applied to the gauge. Suppose that  $R_1$  is the active gauge. If the bridge is balanced then the voltage at points 1 and 2 is half the supply voltage.  $V_1 = V_2 = V_s/2$

When  $R_1$  changes its resistance by  $\Delta R$  the voltage at point 1 becomes:

$$V_s R / (2R + \Delta R) \quad (\text{using ratio of resistances})$$

The output becomes

$$V_o = V_2 - V_1 = V_s/2 - V_s R / (2R + \Delta R)$$

$$V_o = V_s \Delta R / \{4R + 2\Delta R\}$$

Dividing top and bottom by  $R$  we get

$$V_o = V_s (\Delta R/R) / \{4 + 2\Delta R/R\}$$

The gauge factor is defined as

$$G = \text{electrical strain/mechanical strain}$$

$$G = (\Delta R/R)/\epsilon \quad \text{so } (\Delta R/R) = G\epsilon$$

Substituting we get

$$V_o = V_s G\epsilon / \{4 + 2G\epsilon\}$$

### WORKED EXAMPLE No.5

Four strain gauges are formed into bridge with only one active gauge. The nominal resistance of all of them is  $120 \Omega$ . The gauge factor is 2.1 and the supply voltage is 10 V. Calculate the strain when the output from the bridge is 20 mV.

### SOLUTION

$$V_o = V_s G\epsilon / \{4 + 2G\epsilon\} \quad \epsilon = 4V_o \div G(V_s - 2V_o) = (4 \times 0.02) \div \{2.1(10 - 0.04)\} = 3.825 \times 10^{-3}$$

**TEMPERATURE EFFECTS**

One of the problems with strain gauges is that the resistance also changes with temperature and so it is vital that each pair of resistors is maintained at the same temperature.

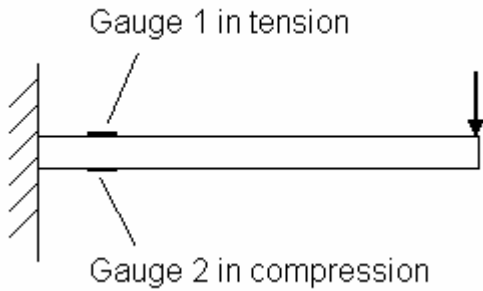

Figure 33

If one active gauge is used, say  $R_1$ , then the other resistor  $R_2$  must be placed near to it and this is best done by using a DUMMY GAUGE fixed close to the active gauge but in a position where it is unstrained. Better still, make  $R_2$  another active gauge and so double the output from the bridge. For example, if a beam is used to produce the strain, one gauge is placed on top and the other on the bottom as shown. Let  $R_1$  increase and  $R_2$  decrease by  $\Delta R$ . The voltage at point 1 becomes

The output becomes

$$V_s(R - \Delta R)/2R \quad (\text{using ratio of resistances})$$

$$V_o = V_2 - V_1 = V_s/2 - V_s(R - \Delta R)/2R$$

$$V_o = V_s \Delta R / \{2(2R + \Delta R)\}$$

Dividing top and bottom by R we get

$$V_o = V_s \Delta R / 2R$$

$$V_o = V_s G\epsilon / 2 \quad \text{which is almost double the output.}$$

If the load cell only produces tension or compression, the active gauges are  $R_1$  and  $R_4$  with  $R_2$  and  $R_3$  being dummy gauges. All 4 gauges are then at the same temperature. This is shown in the diagram.

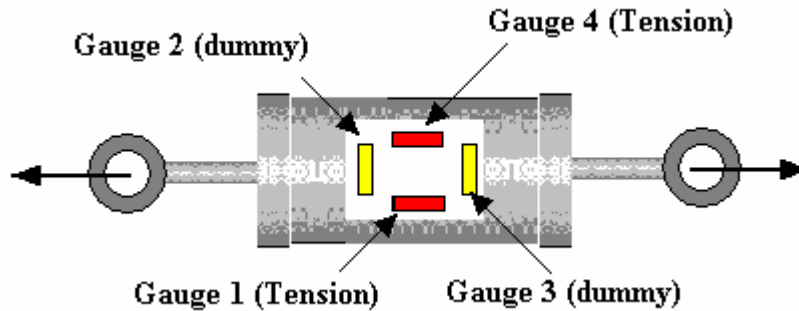

Figure 34

The voltage at point 1 becomes

$$V_s R / (2R + \Delta R)$$

and at point 2 becomes

$$V_s (R + \Delta R) / (2R + \Delta R)$$

The output becomes

$$V_o = V_2 - V_1 = V_s \Delta R / (2R + \Delta R)$$

Dividing top and bottom by R we get

$$V_o = V_s (\Delta R / R) / \{2 + \Delta R / R\}$$

$$V_o = V_s G\epsilon / (2 + G\epsilon)$$

This is double the output of a single active gauge and fully temperature stable.

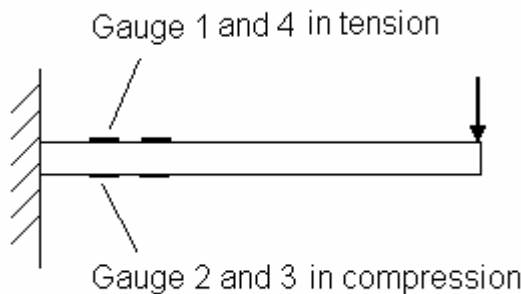

Figure 35

If a beam is used in the load cell, all 4 gauges may be made active as shown.

The output at point 1 becomes

$$V_1 = V_s (R - \Delta R) / 2R$$

and at point 2 becomes

$$V_2 = V_s (R + \Delta R) / 2R$$

The output becomes

$$V_o = V_2 - V_1 = V_s \Delta R / R \quad V_o = V_s G\epsilon$$

This is 4 times the output of a single active gauge and fully temperature stable.

### SELF ASSESSMENT EXERCISE No.3

1. A strain gauge is glued to a structure. It has a gauge factor of 2.1 and a resistance of 120.2  $\Omega$ . The structure is stressed and the resistance changes to 120.25  $\Omega$ . Calculate the strain and convert this into stress.

Take  $E = 205 \text{ GPa}$

(Answer 40.6 MPa)

2. A strain gauge has a resistance of 120.6 Ohms at 20°C. Calculate its resistance at 30°C.  
 $\alpha = 8 \times 10^{-6} \Omega/\Omega^\circ\text{C}$ .

(Answer 120.61  $\Omega$ )

3. Describe how to eliminate temperature error in a strain gauge bridge when it has
- one active gauge.
  - two active gauges.
4. A STRAIN GAUGE has a gauge factor of 2.2. It is glued to tensile test piece and the resistance before straining is 119.8  $\Omega$ . The test piece is stretched and the resistance goes up to 120  $\Omega$ . Calculate the following. The modulus of elasticity  $E$  for the test piece is 200 GPa.
- The strain in the test piece. ( $7.588 \times 10^{-4}$ )
  - The stress in the test piece. (15.18 MPa)

#### **SELF ASSESSMENT EXERCISE No.4**

1. State what each of the sensors below measures (flow, temperature and so on)
  - a. Thermocouple.
  - b. Potentiometer.
  - c. Thermistor.
  - d. Optical fringes.
  - e. Venturi meter.
  - f. Pitot tube.
  - g. Bimetallic type.
  - h. Platinum resistance probe.
  - i. D.C. type generator.
  - j. L.V.D.T.
  - k. Bourdon tube.
  - l. Orifice meter.
  - m. Piezo electric.
  
2. State two types of sensors that could be used to measure each of the following.
  - a. Speed of revolution.
  - b. Flow rate of liquids.
  - c. Pressure.
  - d. Temperature.